



HOSHIZAKI

REFRIGERATED CABINET 2/1 GN SUR-65EG-R-C-U



MODEL DESIGNATION EXAMPLE:

SUR - 65EG R C

Legs or Castors

C : Castors Ø 100 mm
L : Legs H = 130-180 mm

Exterior finish

R : Inox AISI 430

Generation and refrigerant

EG : Generation 4 and HC refrigerant

Exterior dimensions

65 : Width 654 mm
135 : Width 1344 mm

Temperature range

SUR : Refrigerator
SUF : Freezer

Option codes:

L : Legs H = 130-180 mm
C : Castors Ø 100 mm

Product code	Product name
877000	SUR-65
877010	SUF-65
878000	SUR-135
878010	SUF-135

Product series: Snowflake GII+
Item number: 877000904



Temperature range
0/+10°C

The Snowflake GII+ series is brought to you by Japanese and Danish engineering excellence, dedicated to simplifying the day-to-day work routines of kitchen staff all around the world.

The technology behind the performance boost of Snowflake GII+ is the tropicalised cooling system enduring up to +40°C. Additionally, the cooling agent of the new generation of Snowflake is the eco-friendly refrigerant R290, a natural gas (HC) that enhances the performance and significantly reduces energy consumption.

The Snowflake GII+ SUR-65EG is a 1-door refrigerated cabinet with a net internal volume of 415 Ltr.

As a product that is designed and built to last, this refrigerated cabinet combines an innovative design concept, premium materials and clever extras:

- Minimum cool air lost: double insulated and extra wide door gaskets help keep the cold air in the cabinet.
- Both interior and exterior are built of stainless steel.
- Anti-tilt mechanism: moulded liners for gastronomy pans and shelves.
- Reversible door for maximum flexibility.
- Removable gaskets and cleaning-free condenser allow you to clean the device thoroughly.
- Accurate, user-friendly digital temperature controls and display.
- Sturdy lockable castors allow easy positioning.
- Automatic defrost maximises efficiency and performance.
- Fan assisted cooling for rapid temperature recovery.
- Secure lockable, self-closing door.

The refrigerant used in all Snowflake GII+ HC models is R290.

This agent is a natural gas which enhances the performance of the cabinet and has, compared to other refrigerants, a minimal global warming potential.

Refrigerant / GWP:
R 290 / 3 - (0.058kg/CO2 eq 0.174kg)

Energy Efficiency Index
EEI: 42.41

Energy consumption
Ecodesign AEC:
548 kWh/year

Climate class:
5

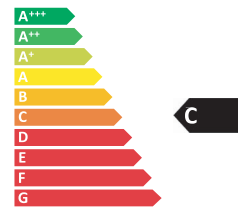

MODEL	Volume, gross	Net usable volume	Maximum number of shelves	Number of shelves	Connection	Connection load (Watts)	Refrigeration capacity at -10°C	Sound level	Insulation
SUR-65EG-R-C-U	600 ltr	415 ltr	22 distance of 60mm	3	230 V, 50 Hz	140 Watt	297 Watt	54 dB(A)	60mm (cyclopentane)



HOSHIZAKI

Product series: Snowflake GII+
Item number: 877000904

REFRIGERATED CABINET 2/1 GN SUR-65EG-R-C-U

Temperature range
0/+10°C

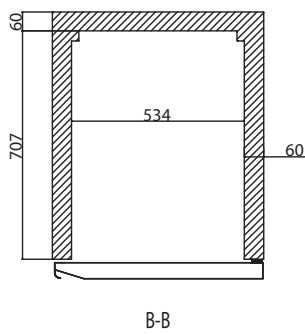
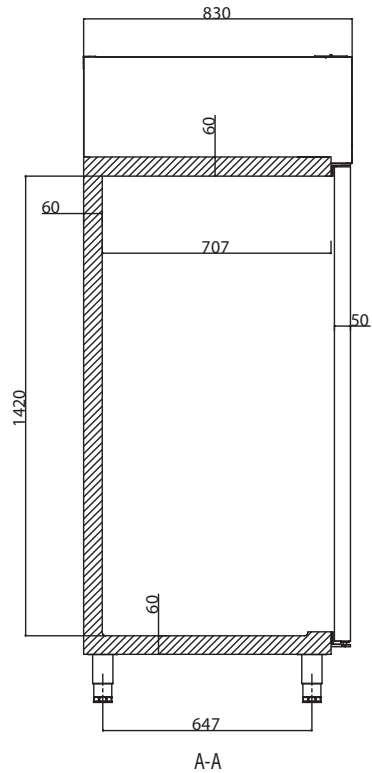
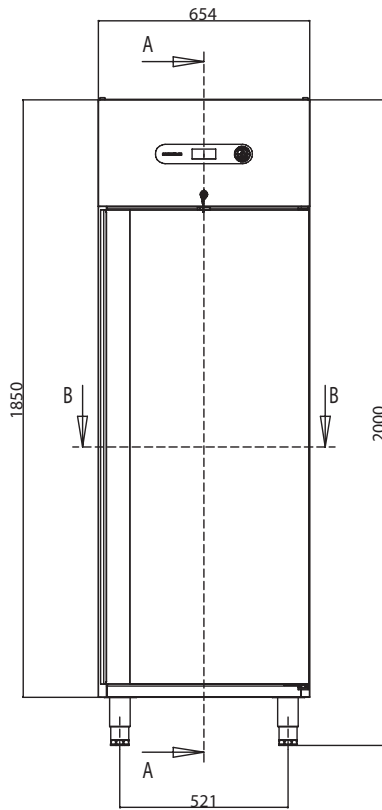

LEG	CASTOR

MODEL	Net dimensions W x D x H	Net weight	Packaged dimensions W x D x H	Packaged weight	Packaged volume
SUR-65EG-R-C-U	654 x 830 x 1977mm	117kg	704 x 880 x 2150mm	122kg	1.33 m ³