



# HOSHIZAKI

## REFRIGERATED CABINET 2/1 GN SUR-135EG-R-C-U



### MODEL DESIGNATION EXAMPLE:

**SUR-135 EG R C**

#### Legs or Castors

C : Castors Ø 100 mm  
L : Legs H = 130-180 mm

#### Exterior finish

R : Inox AISI 430

#### Generation and refrigerant

EG : Generation 4 and HC refrigerant

#### Exterior dimensions

65 : Width 654 mm  
135 : Width 1344 mm

#### Temperature range

SUR : Refrigerator  
SUF : Freezer

#### Option codes:

L : Legs H = 130-180 mm  
C : Castors Ø 100 mm

Product code	Product name
877000	SUR-65
877010	SUF-65
878000	SUR-135
878010	SUF-135

Product series: Snowflake GII+  
Item number: 878000904



Temperature range  
0/+10°C

The Snowflake GII+ series is brought to you by Japanese and Danish engineering excellence, dedicated to simplify the day-to-day work routines of kitchen staff all around the world.

The technology behind the performance boost of Snowflake GII+ is the tropicalised cooling system enduring up to +40°C. Additionally, the cooling agent of the new generation of Snowflake is the ecofriendly refrigerant R290, a natural gas (HC) that enhances the performance and significantly reduces energy consumption.

Both interior and exterior are built of anti-corrosion stainless steel, which is among the best choices for hygienic and food safe cooking environments.

The Snowflake GII+ SUR-135EG-R-C-U is a 2-door refrigerated cabinet with a net internal volume of 797 Ltr.

As a product that is designed and built to last, this refrigerated cabinet combines an innovative design concept, premium materials and clever extras:

- Minimum cool air lost: double insulated and extra wide door gaskets help to keep cold air in the cabinet.
- Anti-tilt mechanism: moulded liners for gastronorm pans and shelves.
- Removable gaskets and cleaning-free condenser allow you to clean device thoroughly.
- Accurate, user-friendly digital temperature controls and display.
- Sturdy lockable castors allow easy positioning.
- Automatic defrost maximises efficiency and performance.
- Fan assisted cooling for rapid temperature recovery.
- Secure lockable, self-closing doors.

The refrigerant used in all Snowflake GII+ HC models is R290.

This agent is a natural gas which enhances the performance of the refrigerated cabinet and has, compared to other refrigerants, a minimal global warming potential.

Refrigerant / GWP:  
R 290 / 3 - (0.085kg/CO2 eq 0.255kg)

Energy Efficiency Index  
EEI: 48.16

Energy consumption  
Ecodesign AEC:  
926 kWh/year

Climate class:  
5

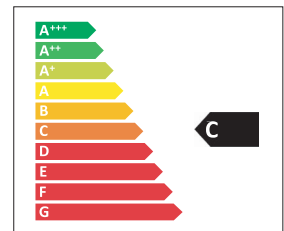

MODEL	Volume, gross	Net usable volume	Maximum number of shelves	Number of shelves	Connection	Connection load (Watts)	Refrigeration capacity at -10°C	Sound level	Insulation
<b>SUR-135EG-R-C-U</b>	1200 ltr	797 ltr	22 x 2 distance of 60mm	6	230 V, 50 Hz	250 Watt	632 Watt	53 dB(A)	60mm (cyclopentane)



# HOSHIZAKI

Product series: Snowflake GII+  
Item number: 878000904

## REFRIGERATED CABINET 2/1 GN SUR-135EG-R-C-U

Temperature range  
0/+10°C

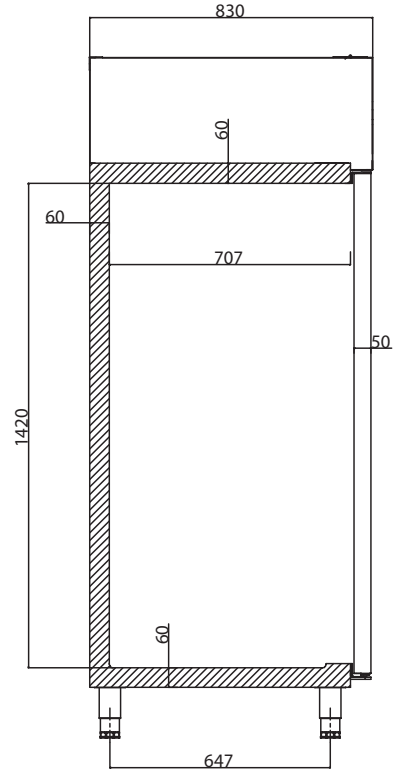
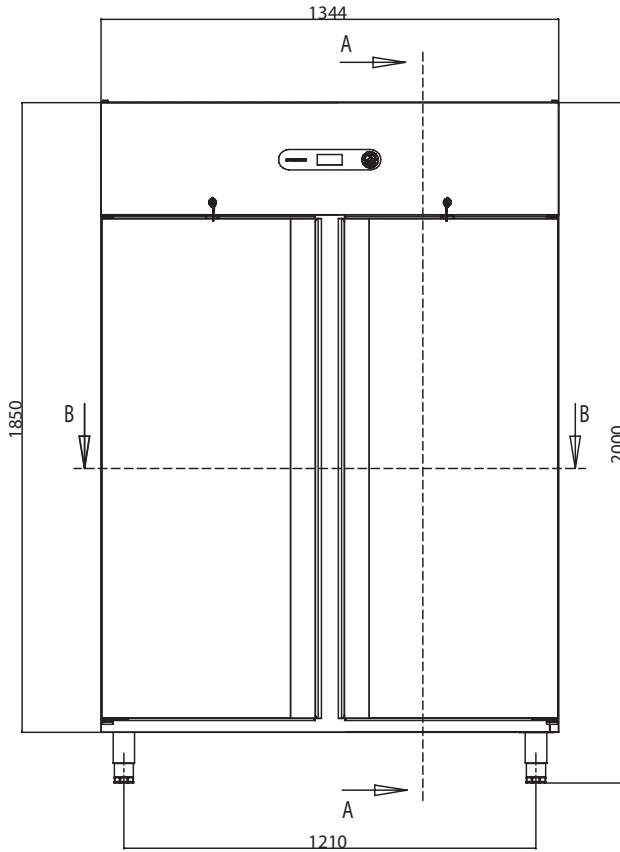

A-A

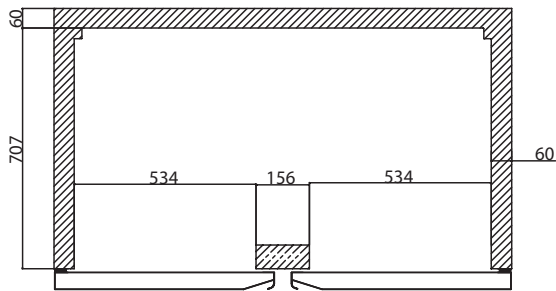

B-B

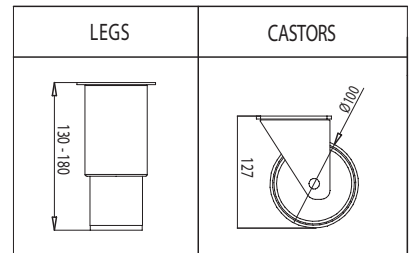

MODEL	Net dimensions W x D x H	Net weight	Packaged dimensions W x D x H	Packaged weight	Packaged volume
<b>SUR-135EG-R-C-U</b>	1344 x 830 x 1977mm	184kg	1394 x 880 x 2150mm	192kg	2.64 m <sup>3</sup>