



Model

NS350HD

Product Description

Slicer, 14", Heavy Duty

Product Code

5S510N



Standard Features

- Designed for handling larger volumes than medium duty range. Recommended for delis, restaurants, supermarkets and canteens
- Hollow ground chromed carbon steel blade
- Powerful twin 'V' belt driven transmission gives a smooth cutting action and silent running
- Easy belt adjustment
- Easy set thickness control allows for precision slicing
- Carriage slides on ball bearings for smooth carriage glide
- Made from high polished, anodised food grade aluminium for durability and hygiene
- Large base to ensure slicer has a large capacity to cope with large products
- Ergonomic design with smooth rounded edges to allow for fast and easy cleaning and improved levels of hygiene
- Fully interlocked and safe guarded for full compliance of CE legislation. This ensures all-round blade protection for ultimate user safety during cleaning
- Built-in, self-aligning sharpening and de-burring unit
- Table / carriage, blade cover, blade and sharpening unit are detachable for easy cleaning
- Transparent slicing guard to ensure ultimate user safety whilst slicing
- Optional voltages and frequencies available on request
- CE Approved

Standard Accessories

- 1 x Knife Remover
- 1 x Flat Head Screwdriver
- 1 x Tasteless Oil

Warranty

Covered by Metcalfe 2-year warranty (1st year parts and labour, 2nd year parts only) and full after sales service

Optional Accessories

| Item |
|------------------------------------|
| Tray Extension Device |
| Stainless Steel Guard |
| Product Hold Bar for Gravity Plate |
| Painting Customisation |

| Item |
|--|
| Serrated Blade |
| Teflon Coated Parts (Blade Cover, Gauge Plate, Blade) |
| Special Arm (Protected) |
| Vegetable Tube |

| Item |
|-------------------------------|
| Stainless Steel Knife Remover |
| Aluminium Knobs |
| Plastic Cover – Medium |

Drawing

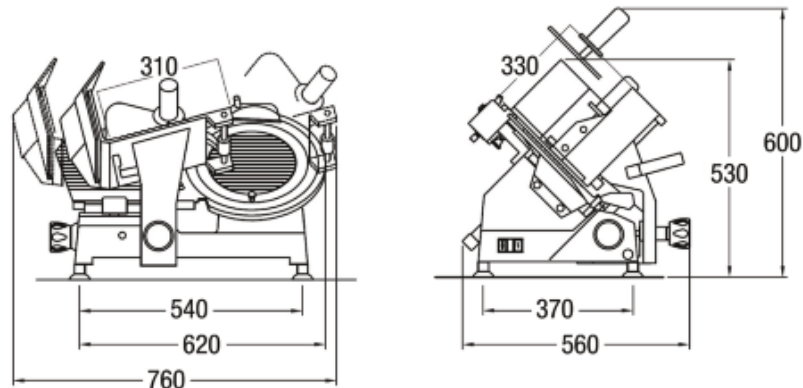

Specifications

| Model | Blade (mm) / (Inch) | Phase (Ø) | Motor (Volt) | Frequency (Hz) | Current (Amp) | Power (kW) |
|---------|---------------------|-----------|--------------|----------------|---------------|------------|
| NS350HD | 350 / 14 | 1 | 220 | 50 | 1.68 | 0.37 |

Capacity

| Model | Cutting Capacity (mm) | | Carriage Movement (mm) | Max Slice Thickness (mm) |
|---------|-----------------------|-------------|------------------------|--------------------------|
| NS350HD | ● 240 | □ 200 x 270 | 290 | 14 |

Dimensions | Shipping Information

| Model | Overall Dimensions D x W x H (mm) | Net Weight (Kg) | Packed Dimensions D x W x H (mm) | Packed Weight (Kg) | Volume (m3) |
|---------|-----------------------------------|-----------------|----------------------------------|--------------------|-------------|
| NS350HD | 560 x 700 x 600 | 36 | 600 x 710 x 520 | 42 | 0.222 |

We reserve the right to alter the specification and technical details for this item at any time without prior notice. 10/2020

