



Model

MP10

Product Description

Planetary Mixer, 10 litre, Heavy Duty

Product Code

5MP10

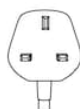

Standard Features

- Heavy duty 10ltr, countertop, belt driven, planetary mixer
- Particularly suitable for bakeries, hotels, restaurants, canteens etc
- Easy to operate
- Planetary mixing action and digital timer ensures perfect results
- High torque motor allows mixing of stiffer doughs and larger batches
- 15 minutes timer
- Digital control panel
- 3 fixed speeds: 135, 243 and 480 rpm
- Easy speed-shifting
- Interlocking bowl guard and bowl lift
- Stainless steel safety guard with ingredient chute and automatic shut-off when guard is opened at any speed
- Overload protection (NVR device)
- Emergency stop button
- Long lasting lubricant providing abrasion resistant transmission
- Timing belt transmission
- All metal and die-cast aluminium body
- Non-slip rubber feet
- Quiet operation

Standard Accessories / Attachments

- 1 x Whisk
- 1 x Beater
- 1 x Dough hook
- 1 x 10 litre Stainless steel bowl

Warranty

Covered by Metcalfe 3-year warranty (1st year parts and labour, 2nd & 3rd years parts only) and full after sales service

Optional Accessories / Attachments

Item	Product Code
Bowl	MPBM10-12-001
Beater	MPBM10-12-002

Item	Product Code
Dough Hook	MPBM10-12-003A
Whisk	MPBM10-12-004

Drawing

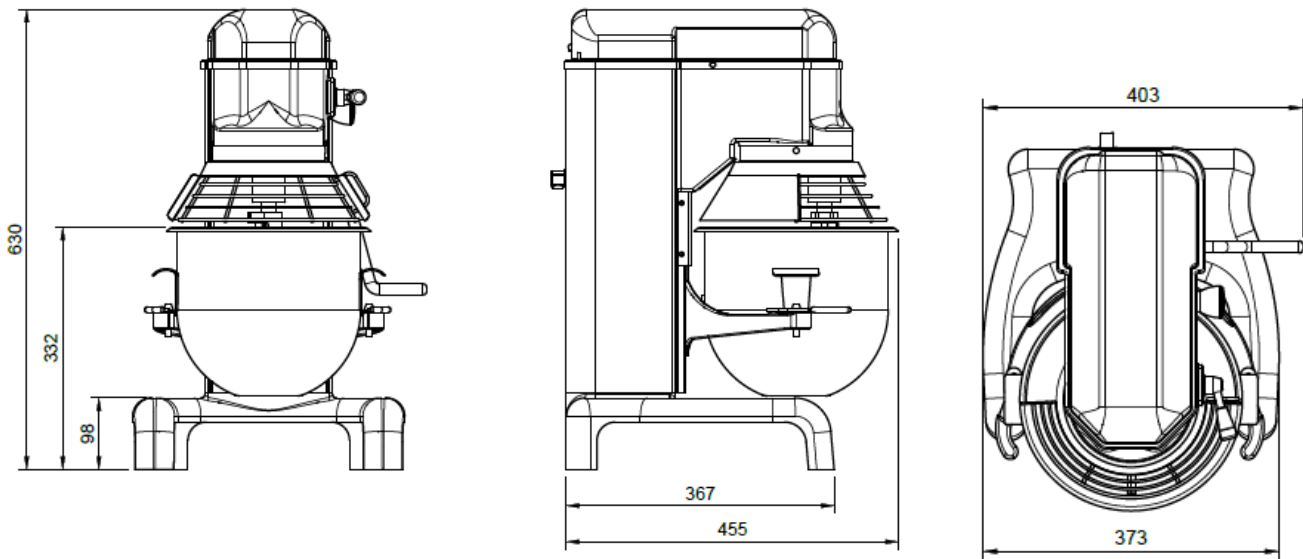

Specifications

Model	Capacity (ltr)	Phase (Ø)	Motor (Volt)	Frequency (Hz)	AMP (A)	Power (kW / hp)	Speed (rpm)
MP10	10	1	220-240	50	3.5	0.25 / 0.33	135 / 243 / 480

Dimensions | Shipping Information

Model	Overall Dimensions D x W x H (mm)	Net Weight (kg)	Packed Dimensions D x W x H (mm)	Packed Weight (kg)	Volume (m3)
MP10	455 x 403 x 630	62	580 x 450 x 800	72	0.209

We reserve the right to alter the specification and technical details for this item at any time without prior notice. 12/2021

Metcalf Catering Equipment Ltd

Haygarth Park
Blaenau Ffestiniog
Gwynedd, LL41 3PF

