

COOKING EQUIPMENT  
**CHARBROILER RANGE**

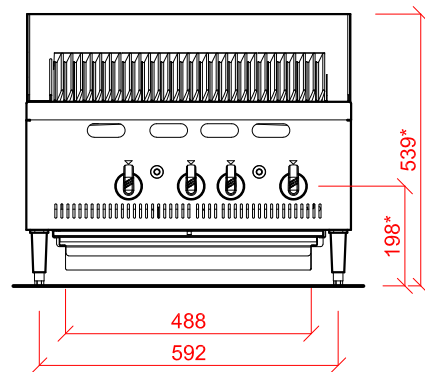

Charbroiler Range - Natural Gas

BCB600-1

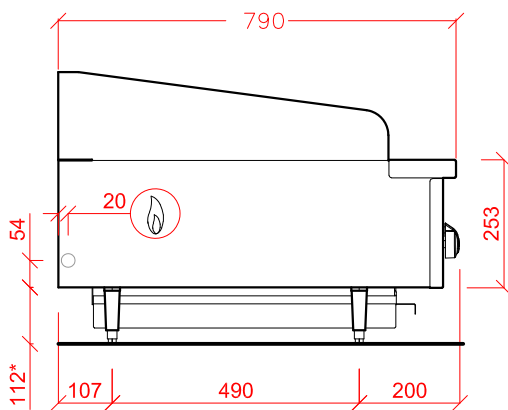
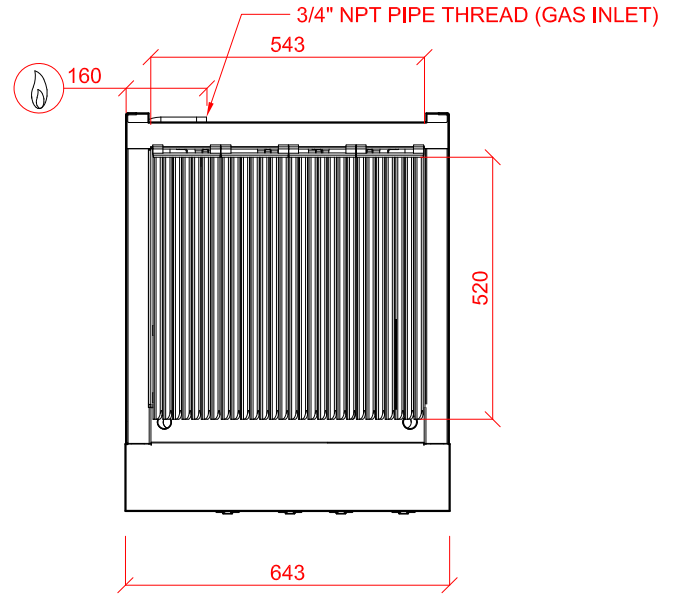

Device Number	Description	Gas	Notes	
BCB600-1	GAS CHARBROILER - (Nat Gas). (WITH PIEZO IGNITION).	14.8kW / (50,520BTU/H)	22mm CONNECTION, 20m BAR	<b>SPECIAL NOTE:</b> INSTALLATION MUST COMPLY WITH CURRENT GAS SAFETY REGULATIONS AND BS 6173 UNIT WEIGHT - 86kg